

U8L080DF



Product Family	Refrigerator
Installation	Built-in
Category	Under counter
Built-in niche	82 - 87
Reference width	Until 60
Reference height	Until 100
Cooling type	Static
Hinge type	Door on door
Hinge position	Right
Reversible door	Yes
EAN code	8017709295479



Aesthetics

Aesthetic	Universale	Side colour	White
Colour	White	Logo	Silk screen
Design	Flat	Door shelves profile color	Silver
Material	Metal sheet	Drawers profile color	Silver
Handle type	Fixed	Color of glass shelf profile	Chrome
Side material	Steel		

Refrigerator compartment features



No. of adjustable shelves	3	Crisper Cover	Yes
Number of fruit and vegetables drawers	1	Type of crisper/vegetable drawers cover	Glass
Type of adjustable shelves	Glass	Internal light in fridge	Yes
Type of crisper/vegetable drawers cover	Standard	Type of internal light (fridge)	LED

Refrigerator Inner Door

No. of door shelves with transparent cover	1	No. of bottle shelves	1
Adjustable door shelves with wire support	Yes	Bottle shelves with wire support	Yes

Other Refrigerator features

Accessories Egg tray

Other technical features

Type of temperature control	Electro-mechanical
No. of compressors	1
Refrigerant gas type	R600a
Refrigerant Quantity (gr)	18 g
Max weight door panel (fridge)	31 kg
Foam agent	Cyclopentane

Performance / Energy Label NEW 2019

			
Annual energy consumption	116 kWh/a	Sum of the volumes of the chill compartment(s) and the unfrozen compartment(s)	134 l
Energy efficiency class	F	Airborne acoustical noise emissions	37 dB(A) re 1pW
Airborne acoustical noise emission class	C	Climate class	SN, N, ST, T
Total net volume	134 l	EEL	125 %

Electrical Connection

Plug	(F;E) Schuko	Voltage (V)	230-240 V
Electrical connection rating	110 W	Frequency (Hz)	50 Hz
Current	0,8 A	Power supply cable length	240 cm

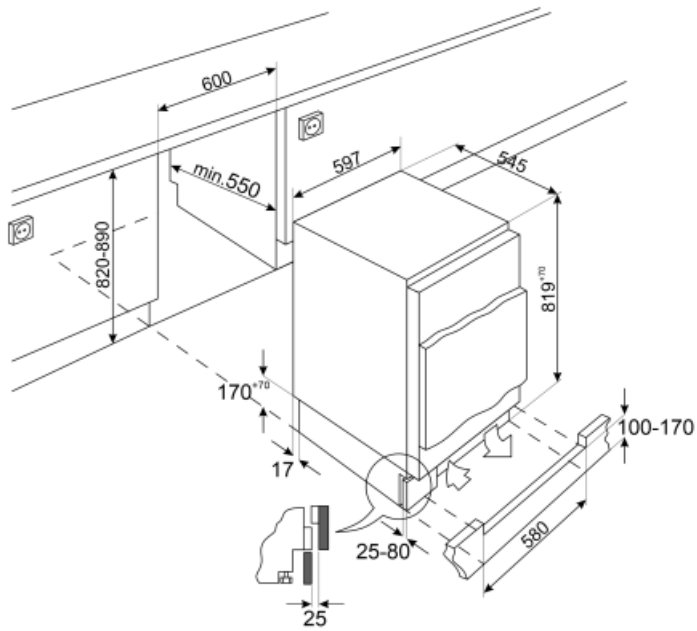

Symbols glossary (TT)

- | | | | |
|--|--|---|---|
|  | A++: Energy efficiency class A++ helps to save up to 20% energy compared to class A. Maximum performance with minimum consumption is guaranteed. |  | LED interior lighting: is a more energy efficient and long lasting way of illuminating the interior of the appliance. |
|  | Built-in niche |  | Energy efficiency class F |